

NOTES: UNLESS OTHERWISE SPECIFIED

- 1 ELECTROFORM REFLECTOR FROM MASTER TOOL WITH SPECULAR SURFACE QUALITY OF 80-50 SCRATCH-DIG PER MIL-PRF-13830B.
- 2 NOMINAL THICKNESS (T) MAY VARY ± T/4 WITHIN .25 OF EDGES.
- 3 REFLECTIVE SURFACE COATING TO BE SEPARATELY SPECIFIED.

REVISIONS			
REV	DESCRIPTION	DATE	APPROVED
Ø	INITIAL DRAWING RELEASE	06/10/96	GRW
A	REVISED DIM TOLERANCES	07/31/17	KEN S
B	REVISED TOLERANCES	07/31/17	KEN S
C	ADDED -.05	07/31/17	GRW
D	ADDED -.06	07/31/17	MM
E	ADDED -.07	07/31/17	GRW
F	UPDATED DRAWING FORMAT	07/31/17	JPH

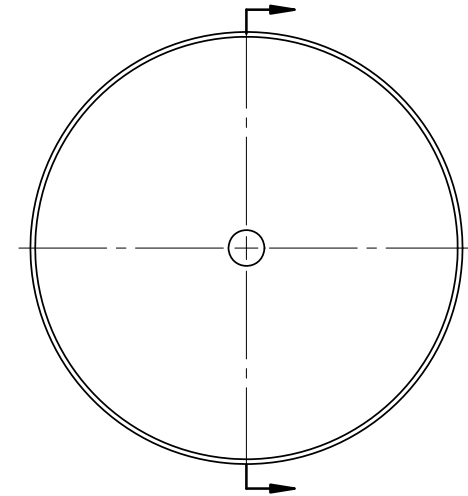
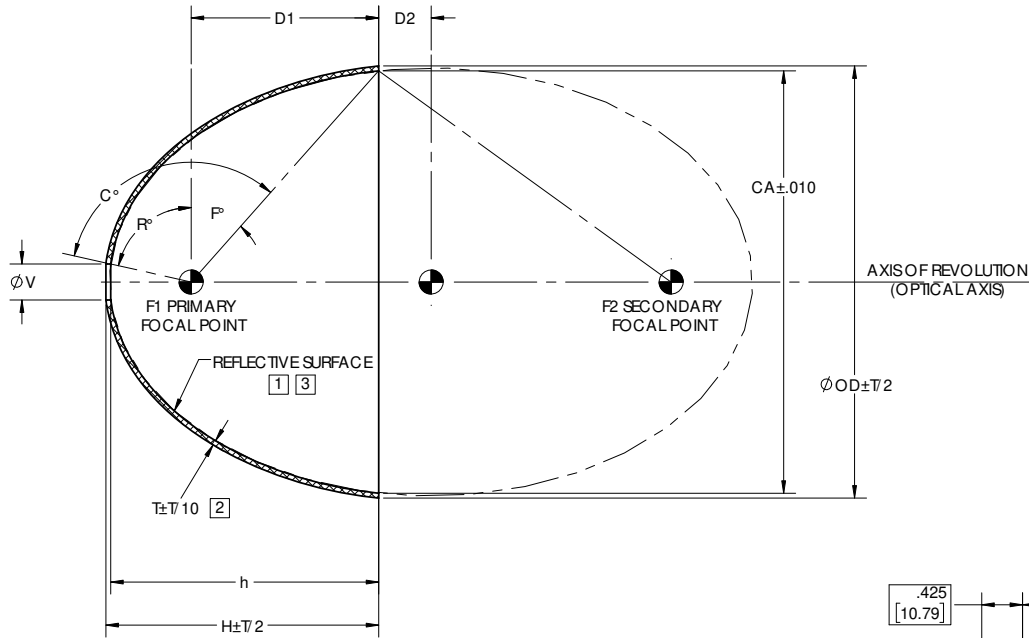

ELLIPSOID GEOMETRY DATA

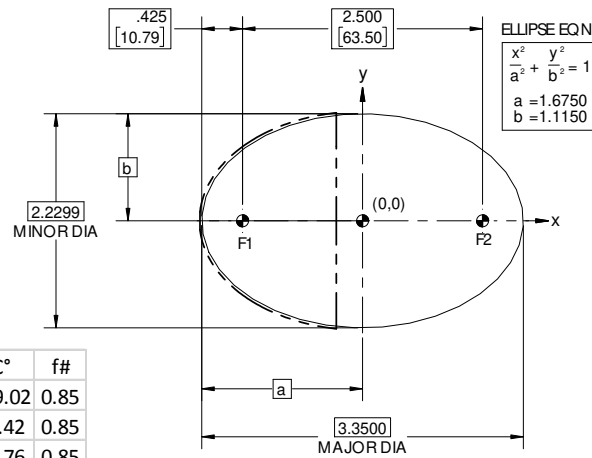

DASH NO.	CA	V	OD	T	D1	D2	H	h	R°	F°	C°	f#
E64	2.200	0.187	2.250	0.025	0.977	0.273	1.421	1.396	77.42	41.60	119.02	0.85
E64-0100	2.200	0.500	2.250	0.025	0.977	0.273	1.385	1.359	56.82	41.60	98.42	0.85
E64-0200	2.200	1.520	2.250	0.025	0.977	0.273	0.994	0.952		41.60	39.76	0.85
E64-0300	2.200	0.250	2.250	0.025	0.977	0.273	1.416	1.391	73.22	41.60	114.81	0.85
E64-0400	2.200	0.625	2.250	0.025	0.977	0.273	1.362	1.334	48.87	41.60	90.47	0.85
E64-0500	1.991	0.500	2.044	0.025	0.496	0.754	0.904	0.878	56.82	26.47	83.29	1.12
E64-0600	2.200	0.187	2.250	0.025	0.977	0.273	1.421	1.396	77.42	41.60	119.02	0.85
E64-0700	1.991	0.625	2.044	0.025	0.496	0.754	0.881	0.854	48.87	26.47	75.34	1.12

NOTE: THE "E64" DASH NO. IS THE THEORETICALLY LARGEST REFLECTOR THAT CAN BE FORMED FROM EXISTING MASTER TOOLING.

UNLESS OTHERWISE SPECIFIED DIMENSIONS ARE IN INCHES (mm) GD&T PER ASME Y14.5-2009 DO NOT SCALE DRAWING		CONTRACT NO. 00-E64		42310 WINCHESTER RD. TEMECULA, CA 92590 WWW.OPTIFORMS.COM	
TOLERANCES		DRAWN JWW	DATE 07/31/17		
FRACTIONS ± 1/16 DECIMALS ± .02 ANGLES ± 1/2°		CHECKED	DATE		
SURFACE ROUGHNESS 63/		ENGR FFS	DATE 07/31/17	REFLECTOR, ELLIPTICAL 2.500"/64mm (F1-F2)	
DEBURR SHARP EDGES & HOLES MAX .015 MAX CHAMFER 3:1 RADIUS .015 MAX FOOT DIAMETER		MATERIAL		SCALE 2:1	
ELECTROFORMED NICKEL - LSSN TYPE 1		FINISH		SIZE C	
APPLICATION		SEE NOTE 3		CAGE CODE 0Y1Y4	
THIRD ANGLE PROJECTION		DWG NO. E64		REV F	
		SHEET 1 OF 1			